

# Technology Expo 2024

Your personal invitation to attend, refreshments provided.  
Come have a productive chat with the leaders in their respective fields of factory automation & process control.

## BLenheim

**Date:** Wed. 15th May 2024  
**Time:** 12.30 pm - 5.30 pm  
**Place:** Marlborough Events Centre  
42A Alfred Street, Blenheim

## NELSON

**Date:** Thurs. 16th May 2024  
**Time:** 12.30 pm - 5.30 pm  
**Place:** Beachside Conference & Events Centre  
70 Beach Road, Tahunanui, Nelson

PRIZES  
TO BE  
WON!





**SEW Eurodrive manufactures a wide range of premium quality reduction geared motor units, AC frequency inverters and servo drive packages for a wide range of industries.**

Typical applications include geared motors and speed controllers for materials handling and fluid handling machinery. We have solutions for everything from heavy mining, steel and lumber applications to high speed, high precision packaging machines. Innovative drive and control systems can be tailored for new builds and plant upgrades. Aseptic solutions include all-stainless steel geared motor units and multi-layer paint protection packages for harsh and hygienic environments.

Our range of gearboxes and motors meet the highest international requirements for efficiency and global representation ensures seamless service and support for exporters.



Automation Sensors / Process Sensors / Plant Network & Machine Control Systems

**ifm New Zealand employs 21 dedicated local staff – committed to help you and your business succeed. We've grown steadily over the last few decades, now servicing >3,000 local businesses across NZ industry. We're proud to deliver >70% of all PO's overnight/nationwide, direct from our NZ stock!**

Founded in Germany when man 1st walked on the moon in 1969. ifm electronic gmbh has developed, manufactured and marketed innovative electronic sensors & related control products into industrial automation & process control applications globally for 50 years. Focused on providing high quality industrial product, featuring innovative design & performance specifications. The company has developed to become a respected market leader. Our focus industries include: OEM's, F&B, Horticulture, Water Treatment, Timber, Pulp & Paper, Packaging, Power generation, Mining & Mobile Machinery. Employing 7,200 staff in 75 countries. ifm staff operate under the motto "close-to-you" (our customers). Delivering quality products, technical support & competitive pricing to all ifm Users. Sound interesting? Call in - we look forward to you showing you our Industry 4.0 ready demo stands.



**Since commencing operations in the 1970's, Pump & Valve Specialties has been dedicated to providing solutions in all fields of fluid handling. We supply pumps, valves and turn-key New Zealand-made fibre glass packaged pump stations to all major industries in New Zealand as well as the Pacific Islands. With 5 strategic locations across the country, the largest range of industrial pumps in New Zealand and over 35 staff, we're here to ensure you have the right solution for handling everything from wine to tomato paste, blood to bitumen, chemicals to water, oil, sewage, and everything in between.**



**Pilz GmbH manufactures & supplies industrial automation & control solutions around the world.** Pilz is a highly successful family-owned and family-oriented company that is renowned for its high quality, high reliability & safety certified products and services which are used across a wide variety of industries. Our friendly and approachable employees operate in over 40 countries worldwide, contributing their commitment, creativity and knowledge to enable Pilz to maintain our position as the leading brand in industrial safety – where every Pilz employee is regarded as an ambassador for safety. A Pilz core value is to ensure a company’s most valuable asset, their staff, can work safely and free from injury, something we are committed to assisting our customers with, here in New Zealand. Through our portfolio of products, services & training.



**SMC - more than pneumatics**

World leaders in pneumatic technology and experts in automation control, SMC’s portfolio of over 12,000 basic products with 700,000 variants covers automation and motion control across 80% of all industries. Local manufacturing and stockholding as well as in-house engineering and design provide customers with rapid delivery of standard products and as well as the opportunity for specialised local design and manufacture by our New Zealand engineering team.

SMC is always innovating and developing new products to suit the market. We have a key focus on energy efficiency, Industry 4.0, vacuum technology, robotic automation which is suited to the needs of industry.



**Data & Digitisation**  
We offer a range of solutions we bracket as Data & Digitisation, these generally leverage the core automation solutions and are used for asset utilisation, productivity and quality.

- SCADA solutions
- Historian
- Reporting
- Dashboards & HMI
- Analytics, Seeq
- Industrial IoT
- Track & Trace
- Manufacturing Execution Systems
- Industry 4.0

**Machine & Process Safety**  
Our safety team can assist at all stages of ensuring plant and machinery are safe and productive.

- Machine/process risk assessment and auditing (summary and full)
- Machine safety validation
- Safety Requirement Specification (SRS)
- Mechanical, pneumatic, hydraulic & electrical design
- Machine safety advice
- TUV certified engineers



**Consult - Design - Deliver**

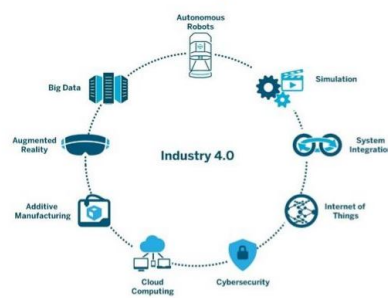

**Measure to gain Control**

Auckland / Tauranga 0800 080 229  
info@nzcontrols.co.nz  
www.nzcontrols.co.nz

**Automation & Controls**  
Core to our business is our extensive automation engineering team. We have experts in most platforms and technologies.

- Functional design / descriptions
- Industrial Networks
- Operation Technology (OT)
- PLC & HMI Programming
- SCADA Systems
- Servos, motion & drives
- Safety control systems
- Vision Systems

**Electrical Engineering**  
We provide certified electrical engineering and designs from the transformer to the sensor

- Electrical engineering
- Electrical design & drafting
- Electrical specification & supply
- Electrical drawings standards
- Cable & termination schedules
- Motor control cabinets
- Electrical panels
- Procurement / management
- EPLAN engineered solutions

**NZ Controls offers electrical engineering and automation services throughout New Zealand and globally.**

Currently we have offices in Tauranga and Auckland, with 30+ engineers providing a range of electrical and automation engineering services to a wide range of sectors and industries.

Our aim is to help our customers link their automation systems into their business, maximise efficiency, productivity and safety. We can provide turnkey solutions or just plug-in specialist resources where needed.

If you want to know what Industry 4.0 really means and how it may help you, come and have a chat.



**Founded in 1961, Rittal has grown to become the largest enclosure manufacturer in the world, a leader in climate control technology and a provider of complete data centre infrastructure. Six locations across Australia and New Zealand service a wide range of industries including:**

- Food and Beverage Processing Plants
- Industrial Process Control Systems
- Mining, Oil and Gas Exploration and Processing
- Machine Tool and Equipment Manufacturing
- Data Centres
- Outdoor Signalling and Communication Systems
- LV Electrical Switchboards

With well over 10 000 products, Rittal has the largest range of industrial and IT solutions supplemented by a vast selection of accessories and modification capabilities. Rittal provides systems and products together with design, consultation, planning, project management and post sale service.

Rittal ANZ service and delivery centres in Sydney, Melbourne, Brisbane, Perth, Adelaide and Wellington. Our modification capabilities ensure the perfect fit solution no matter what your application. Rittal's German engineered, highest quality products are backed by a worldwide team of 10 000 committed staff, 10 high-tech production facilities and 63 international subsidiaries. Rittal is your local global provider of market leading technology.



**HD Process NZ Ltd, specialises in hygienic processing equipment to meet all food, wine, honey and dairy industry needs. The range includes stainless steel valves, filters, pumps and tank equipment.**

Currently the company has 5 full-time sales staff in New Zealand. It has been working with food production related companies in New Zealand for over 22 years. As well as assisting to specify off-the-shelf solutions HD process works with its customers to deliver bespoke solutions.

The off the shelf range typically includes food grade lobe, centrifugal and progressive cavity pumps, butterfly and ball valves, sanitary stainless steel filters, man-ways, tube in tube heat exchangers and a range of general tank equipment.

Please talk to one of our sales staff if you have an interest in getting technical expertise with your product range.

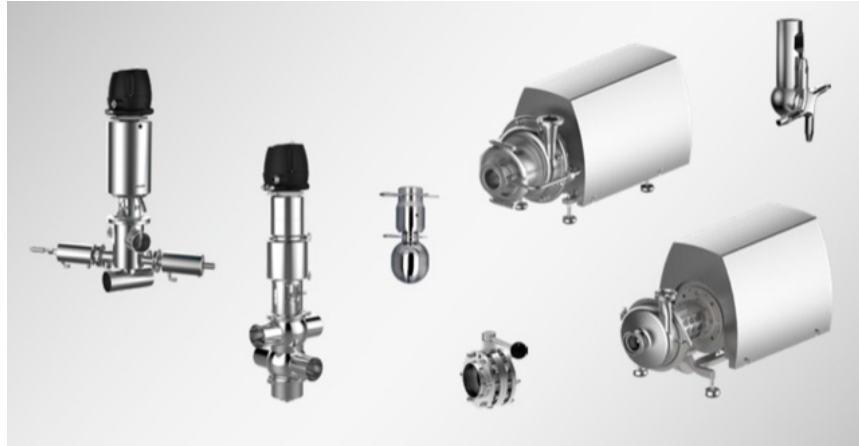

**GEA is present where you are - from Cape Reinga to Bluff. With process and equipment offerings from the farm to the table GEA has a wide range of technologies in its catalogue.**

Within the Equipment business area we have pumps, valves, heat exchangers, cleaning equipment, product recovery systems, strainers/filters, homogenisers, separators/decanter and more.

These are supported in your plant by an After Sales team including locally held spares stock for all equipment and a skilled field service team.



powered by  
**EDIP**



**With more than 35 years in New Zealand and 70 years global experience, Burkert specialise in a number of technologies with Hygienic and Water Treatment applications.**

Utilizing Burkert's unique EDIP communication a wide range of process valves and instrumentation can be interfaced with all of the major networking protocols. With world-best German engineered and manufactured solenoid valves, process and control valves, proportional valves, process pneumatics, instruments, sensors, microfluidics and mass flow control products all products are designed to work together for sleeker results especially with networked systems.

At their Auckland and Sydney Systemhaus, Burkert's local engineering teams develop turnkey process automation systems based on our world-best technologies. As product and system network specialists, our project teams deliver the best of both worlds, with turnkey automation packages developed by product and network experts. The Burkert engineering team works in partnership with industry to design, build and commission complete systems, and has worked with some of the best known names in New Zealand.



### Your Robotic, Automation and Conveyor Experts!

We deliver high quality robotic and automation solutions to help increase productivity and quality while reducing production costs, which in turn helps you build a strong competitive advantage in your industry.

With over 35 years' experience and over 250 robots commissioned and installed globally, our custom solutions are designed to meet the requirements for today's highly competitive manufacturing industry. We fully support our customers with world-leading brands and excellent technical support and service.

We position ourselves as your partner when it comes to robotics and automation, taking a collaborative approach. We work closely with our customers to fully understand pain points in your process and make recommendations for improvements with our knowledge and experience in the industry.

Our team of automation consultants can discuss your process in depth to assist you in building a business case that demonstrates real savings through improving production processes, investing of capital equipment, and staff training.

Discuss your robotic automation application with New Zealand's manufacturing industry experts!



### Looking for a trusted compressed air partner? Look no further than KAESER Compressors NZ Ltd.

KAESER Compressors NZ Limited boasts more air, more savings, and more benefits to you, and your company's compressed air requirements. KAESER Compressors is one of the largest and most successful suppliers of air systems with over 6,600 employees worldwide. From the state-of-the-art production facility in Coburg, Germany, KAESER is proud to manufacture its extensive range of stationary, low pressure and portable compressors; which are exported globally.

KAESER Compressors serves New Zealand from its facilities in Auckland, alongside a dedicated network of authorised partners strategically located nationwide. In addition, KAESER recently expanded its direct operations and now provides local sales and service support throughout the Lower North Island – including The Bay of Plenty, Tauranga, Rotorua, Palmerston North, Wellington and the surrounding Greater Wellington, Wairarapa, and Manawatu-Wanganui regions.

When you choose KAESER, you get so much more. KAESER Compressors NZ Limited offers 24/7 service support nationwide as well as technical analysis of your compressed air station, and advice on a range of bespoke solutions. Our expert team of certified KAESER technicians are on-hand to provide one-on-one support to ensure that your compressed air system operates at its optimum capability; reliably and efficiently throughout its lifetime.

With KAESER compressed air equipment, you can be assured that you are investing in high-quality, energy-efficient, and Industry 4.0 ready technology that delivers more air and more savings. Join us at Roadshow events in 2024 to learn more!